

ADVANCED HISPINNER™

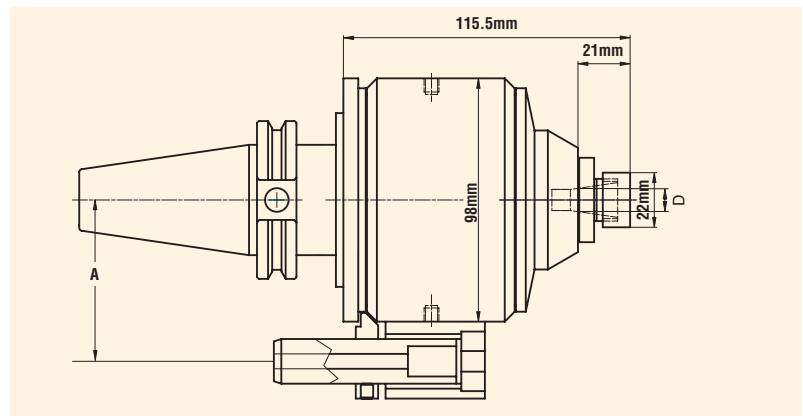

Features

- Developed especially for finish
- Tempered and ground gears
- Four pre-loaded spindle bearings
- Dust protection
- Up to 36,000 rpm
- Gear ratio: 10:1
- Wrenches are included
- 35, 45 and HSK taper available as special quote



Part Number	Taper	A	Weight (lbs.)	D	Max-RPM
C40HSP-ETS14-115	CAT40	65	11	0.5-8 mm	36,000
C50HSP-ETS14-115	CAT50	80	16	0.5-8 mm	36,000
B40HSP-ETS14-115	BT40	65	12	0.5-8 mm	36,000

* Positioning block not included.

** ETS14 Collets available on page 31.

Positioning Block

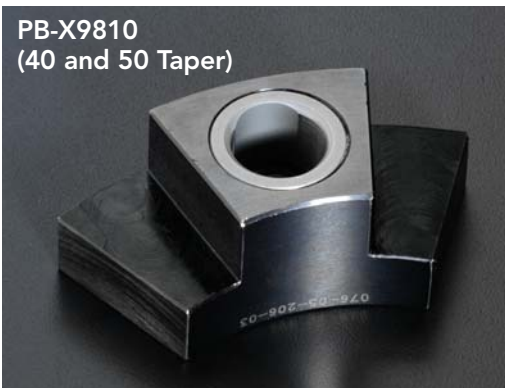

PB-X9810
(40 and 50 Taper)

